

Hydrogen Fuel Cell Vehicle; Current Status and Future Prospect

Anmol Saka¹, Varinder Singh²

¹M. Tech Student at Rayat Bahra University, Mohali, (Punjab), India

²Asst. Prof. Dept. Of Mechanical Engineering Rayat Bahra University, Mohali, (Punjab), India

Abstract:

The hazardous effects of pollutants from conventional fuel vehicles have caused the scientific world to move towards environmentally friendly energy sources. Though we have various renewable energy sources, the perfect one to use as an energy source for vehicles is hydrogen. Like electricity, hydrogen is an energy carrier that has the ability to deliver incredible amounts of energy. Onboard hydrogen storage in vehicles is an important factor that should be considered when designing fuel cell vehicles. In this study, a recent development in hydrogen fuel cell engines is reviewed to scrutinize the feasibility of using hydrogen as a major fuel in transportation systems. A fuel cell is an electrochemical device that can produce electricity by allowing chemical gases and oxidants as reactants. With anodes and electrolytes, the fuel cell splits the cation and the anion in the reactant to produce electricity. Fuel cells use reactants, which are not harmful to the environment and produce water as a product of the chemical reaction. As hydrogen is one of the most efficient energy carriers, the fuel cell can produce direct current (DC) power to run the electric car. By integrating a hydrogen fuel cell with batteries and the control system with strategies, one can produce a sustainable hybrid car.

Keywords: hydrogen; fuel cell; battery; clean transportation; electric vehicle

1. Introduction

Energy is a factor determining a country's economy, infrastructure, transportation, and standard of life. The problem faced globally is the disparity between the consumption and the availability of energy. All nations are presently depending upon fossil fuel for the energy production, and these fossil fuels are not sustainable sources. To supply the energy demands of the more rapidly increasing global population, it is essential to upgrade to an alternative, sustainable energy source that does not negatively affect the environment [1,2]. In recent decades, the United States has been putting emphasis on the environmental impact of the transportation sector and reducing petroleum dependence. Depletion on non-renewable conventional fuels is one of the main issues of the modern energy scenario, which makes the state of the energy industry unsustainable, and it also causes environmental problems such as the greenhouse effect [3,4]. Today, the proportion of fossil fuel use is still high, and it is projected that it will account for approximately 75% of energy production in 2050 [5]. Overall, the current energy scenario has many downsides. However, there exist many sustainable energy sources, and if their use increases, the scenario will be much more optimistic for future generations. It is predicted by environmentalists that the worst-case scenario of global warming

and its effect will not be reached because of different initiatives. Over the last two decades, vehicles have become more fuel efficient, and hybrid electric vehicles are becoming more common. One of the fastest growing alternative *Appl. Sci.* **2019**, *9*, 2296; doi:10.3390/app9112296 www.mdpi.com/journal/applsci energies in vehicles is electricity. As with conventional energy sources such as petroleum and coal, electricity is not a primary energy source. A fully charged battery is an energy carrier. Battery electric vehicles (BEVs) are highly efficient at converting energy from the grid into tractive force, and they can recover energy during drives by utilizing regenerative braking. One major drawback of BEVs is that they usually have a limited range due to the size and the cost of batteries necessary for vehicle power and energy requirements. The “refueling” of the battery systems can also take several hours, rather than a few minutes with a conventional vehicle (CV). To use advantages of both electric and conventional vehicles and to bridge the gap between CVs and BEVs, an alternative is considered. Hydrogen is a chemical energy carrier that has the capability to produce electricity up to 39.39 kWh/kg, which surpasses the energy density of most batteries. A fuel cell (FC) has a direct analogy to an internal combustion engine (ICE). An ICE converts chemical energy stored in the fuel supplied to the engine to produce rotational mechanical energy [6]. The rotational energy produced is then either used to propel a vehicle or focused through a generator and converted into electrical energy. An FC acts much in the same way as an ICE in that chemical energy is directly converted into electrical energy in the FC, but in an environmentally friendly process [7–12]. Unlike a battery that drains while it is used to power electrical components, internal combustion engines and fuel cells act as continually operational power sources as long as fuel is being provided to them [13]. Hence, it is projected that the hydrogen fuel cell can overcome the disadvantages of BEVs, making hydrogen the transportation fuel of the future.

2. Hydrogen as a Transportation Fuel

Hydrogen is the simplest form of all molecules; it has the lowest energy content by volume, but it has the highest energy content of any fuel by weight. It is available in the atmosphere as gas and in water as liquid. Due to the high energy content of hydrogen, it is employed as a fuel in applications such as FCs and rockets. Hydrogen creates zero harmful emissions, which is one of the most significant drawbacks of fossil fuels, and the heating value of hydrogen is three times higher than that of petroleum. There is a hefty production cost involved with hydrogen, since it is a manmade fuel, costing about three times more than petroleum refining [14]. Substantial amounts of research are dedicated to creating an efficient and sustainable way to produce hydrogen and applications for hydrogen in transportation engines. Automobile manufacturers such as Honda, Toyota, and Hyundai have started to manufacture fuel cell vehicles (FCVs) with hydrogen as fuel. These FCVs are currently available in North America, Asia, and Europe, and have primarily been bought by early adopters. The current consumers—early adopters—are primarily highly educated people, high income families, those with larger household units, those willing to change their lifestyle, and those with other similar attributes [15]. As of June 2018, there have been over 6500 FCVs sold to consumers. California is the leading market for FCVs, with nearly 3000 FCVs being delivered there out of the 5233 vehicles sold globally due to the state housing the largest network of hydrogen refueling stations in the world and automakers selling the vehicles there. Presently, several automakers are promoting FCVs to consumers, which are often compared to BEVs. Both BEVs and FCVs offer zero tailpipe emissions, the ability to be fueled using renewable and sustainable energy sources, and use electric motors. The most notable differences between FCVs and BEVs are the driving range and the refueling style. FCVs have

above a 300-mile driving range and can be refueled in less than 10 min at a hydrogen refueling station, which is more comparable to a traditional ICE fossil fuel powered vehicle. Hydrogen has greater potential for use as a fuel in the future. It is estimated that, by the year 2030, the cost of fuel cells will be competitive with ICEs based on the technological improvements being made and the increased availability [14]. One of the main hurdles that mass hydrogen use faces is more efficient storage. Because of the low density of hydrogen, it cannot be stored as easily as traditional fossil fuels. Hydrogen requires compression, cooling, or a combination of them. The most favorable method of hydrogen storage is physical containment, specifically in compressed tanks, because they are readily available. All composites (Type IV) are primarily used, and sometimes metal lined composites (Type III) are used. The fill time of these tanks is competitive with fossil fuels when the hydrogen is pre-cooled. Cost is the main setback for the wide scale use of compressed hydrogen (CH₂) tanks, because the material and the assembly are expensive. Another potential setback is the public's concern of using such high pressure (70 MPa) storage tanks in vehicles [16]. An alternative to traditional CH₂ tanks that is still being researched is a tank with an internal skeleton, which is a complex design of struts in tension within the tank to resist the forces of the compressed gas. Liquid hydrogen (LH₂) storage has improved significantly, achieving the best specific mass (15%) of any other automotive hydrogen storage system [17]. Energy efficiency is decreased when liquid hydrogen is used. Boil off is an area that needs improvement before LH₂ systems can be widely accepted. A promising alternative design is a cryo-compressed tank in which hydrogen is highly compressed at cryogenic temperatures. More studies must be done on this method to determine long term durability and public acceptance of the system. Hydride storage systems require substantial research and progress to meet the requirements for large scale use. The most well studied hydride is NaAlH₄, but it does not have the capacity necessary for application. Based on the results of the few existing studies, it is indicated that tanks with no internal heat transfer elements could be constructed based on the moderate heat of absorption of hydrogen on surfaces [18]. Though hydrogen presence is abundant in the atmosphere, it is not in the purest form. Hydrogen can be extracted from water, hydrocarbon fuel, hydrogen sulfide, and other chemical elements [19]. The energy that is used to produce hydrogen from its associated elements requires external energy, such as thermal, electrical, photonic, and biochemical energy. The chemical element, ammonia, has a high percentage of hydrogen within and was proposed as a fuel for internal combustion engines through onboard decomposition to hydrogen and nitrogen [20,21]. Hydrogen can be extracted from either non-renewable or renewable energy sources. Hydrogen production from renewables is always environmentally friendly, whereas the hydrogen produced from non-renewables emits greenhouse gases (GHG) [22,23]. Hydrogen production from the waste biomass using electrochemical reactions is GHG-less, and it does not require a large amount of energy or high production costs. Possible biomass feedstocks are bread residue, cypress sawdust, and rice chaff [24,25]. Similar to these, newspaper could be used to produce hydrogen by direct electrolysis. Newspaper is composed of 69.2% cellulose and 11.8% lignin, and it is decomposed into monosaccharides and disaccharides as well as aliphatic keto acid in the solvent H₃PO₄ under conditions similar to electrolysis [26,27]. Hydrogen can also be generated by the electrolysis of humidified methane [28].

3. Hydrogen Storage in FCVs

Hydrogen storage is the one of the most important research issues in the development of FCVs. Hydrogen storage systems are under development to introduce new methods to meet the needs of customers. Due to

hydrogen's low energy-density, it is difficult to store enough on-board a vehicle to obtain adequate driving-range without the storage container being too large or too heavy. Figure 1 shows a hydrogen FCV with on-board storage of compressed gas [29]. Hydrogen storage techniques and the required research in this area are summarized in the following points.

3.1. Pressurized Tank Storage

Pressurized tanks of enough strength—involving impact resistance for safety in collisions—are made of carbon-fiber wrapped cylinders. Compressed hydrogen in such tanks has been illustrated at a pressure of 34 MPa with a mass of 32.5 kg and a volume of 186 L, which is adequate for a 500-km range. The tank volume is about 90% of a 55-gallon drum, which is large for individual automobiles. While the 6 wt% goal can be obtained, the tank volume is problematic. Pressures of 70 MPa have been achieved, and in 2002 in Germany, Quantum Technology's 10,000 psi (68 MPa) on-board storage tank was certified [30]. The office of technology policy report [31] says that Toyota and Honda vehicles available for lease in late-2002 use hydrogen stored in high-pressure containers [32]. Nevertheless, unlike other gases, enough hydrogen cannot be stored in the tank because of its low density. Liquid hydrogen storage at low temperatures is not appropriate for normal vehicle use, although research on this feasibility is being continued at a low level by some manufacturers. Moreover, a liquid hydrogen storage system loses up to 1% of its storage volume per day by boiling, and liquid hydrogen requires high refrigeration to keep the hydrogen at 20 K [31].

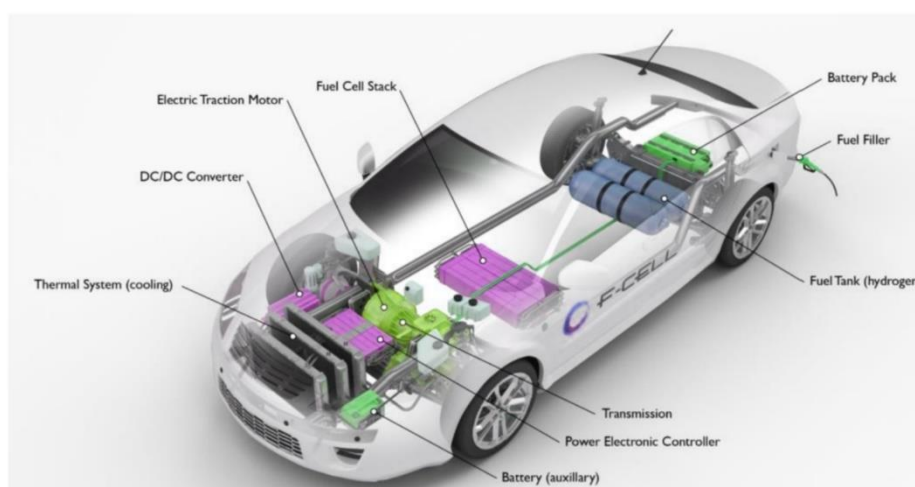

Figure 1. Fuel cell vehicle with on-board storage [29].

3.2. Hydrogen Uptake in Metal-Based Compounds

Metal hydration can be employed to store hydrogen below 3 or 4 MPa at above room temperature; however, the metals induce too much additional weight for most vehicles and are also expensive [33]. It has been found that lithium nitride can reversibly store large amounts of hydrogen. This material stores hydrogen rapidly in the temperature range of 170–210 °C and obtained a 9.3 wt% uptake when the sample was held at 255 °C for 30 min. Under high vacuum (10–9 MPa, 10–5 mbar) about two-thirds of the hydrogen was released at temperatures below 200 °C. The remaining third of the stored hydrogen required temperatures above 320 °C for release. The hydrogen was taken up as lithium amide (LiNH₂) and lithium hydride (LiH). The authors suggested that the related metal-N-H systems should be studied to find more practical pressures and

temperatures for a hydrogen storage system [34].

3.3. Cryogenic Liquid Hydrogen Storage

In the cryogenic liquid storage method, hydrogen is stored in the liquid form by getting to the cryogenic temperature of $-259.2\text{ }^{\circ}\text{C}$. Liquid hydrogen (LH_2) is low density, and 1 L of liquid hydrogen weighs only $71.37 \times 10^{-3}\text{ kg}$. One liter of hydrogen can produce electricity of 8.52 MJ. Maintaining the hydrogen at such a low temperature is highly challenging and requires insulation, thus increasing the cost. Liquid hydrogen becomes explosive when it mixes with certain other gases, thus before refilling the tank with hydrogen, one should use nitrogen gas to drain the residual gases present inside the tank [35–37].

4. Principles of Fuel Cell

There are various types of FC systems. However, the principle of their function is similar. For a fuel cell system, three pillars are required: an anode, a cathode, and an electrolyte. FCs are categorized by the type of electrolyte material used. An FC can be composed of hundreds of individual cells, but each has the three same fundamental components. The electrolyte is located between the cathode and the anode. Figure 2 depicts a schematic of a polymer electrolyte FC (PEMFC) operation diagram [38]. This FC type is also known as a proton exchange membrane FC. The PEMFC is what is most commonly used in mobile power applications, such as vehicles. While the electrolyte material used varies depending on the type of FC, the general function of the FC is as follows—fuel (pure hydrogen) is fed into the anode compartment of the fuel cell while air or pure oxygen is fed into the cathode side of the FC. On the anode side of the cell, electrons are separated as the gas tries to make its way through the electrolyte membrane. The membrane acts as a filter to separate the electrons and the hydrogen ions while only allowing the hydrogen ions to pass through. In the cathode compartment, the hydrogen ions that passed through the membrane combine with the oxygen atoms from the air supply to produce H_2O as a by-product; heat is also produced as a by-product [39]. Unlike internal combustion engines, where the fuel is mixed with air and fuel, there is separation of the fuel and the oxidant with no combustion of the fuel in an FC. Therefore, FCs do not produce the harmful emissions that internal combustion engines produce.

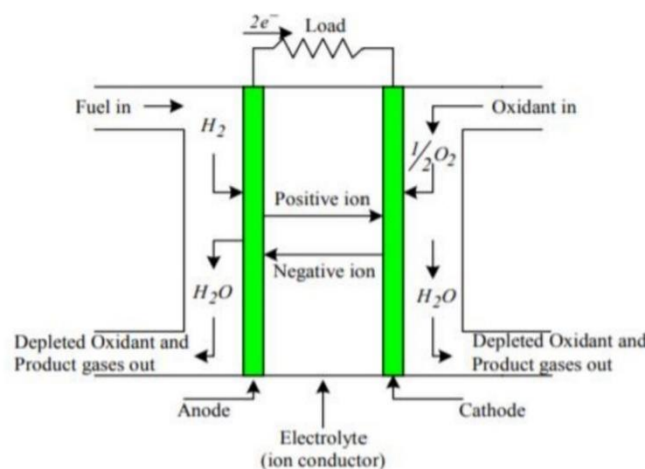

Figure 2. Fuel cell operation diagram [38].

4.1. Types of Fuel Cell

sFC systems are classified by the type of membrane they use. Table 1 shows some of the more common FCs and the type of membrane each uses.

Table 1. Classification of fuel cell systems based on the employed membrane [40].

Fuel Cell	Abbreviation	Membrane
Solid Oxide Fuel cells	SOFC	Yttria-stabilized zirconia
Direct methanol fuel cell	DMFC	Solid polymer electrolyte (Nafion)
Phosphoric Acid fuel cell	PAFC	Phosphoric Acid (H ₃ PO ₄)
Polymer electrolyte fuel cell Or Proton exchange membrane	PEMFC	Solid polymer electrolyte (Nafion)
Alkaline fuel cell	AFC	Aqueous solution Potassium Hydroxide (KOH)

4.1.1. Solid Oxide Fuel Cell (SOFC)

A common stationary power FC is a solid oxide fuel cell [41]. SOFCs conduct ions in a ceramic membrane at high temperatures. In SOFCs, the ceramic usually is a yttrium stabilized zirconia (YSZ) that will conduct oxygen ions (O₂), but other ceramics conduct hydrogen ions. Solid oxide fuel cells operate at elevated temperature ranges, usually around 650–800 °C. An advantage to an SOFC is that, due to the elevated temperature ranges and oxidizing ion (O⁻) transport, these fuel cells can handle a variety of fuels [39]. A common use for these fuel cells is as backup power for cell phone towers. The reactions associated with solid oxide fuel cells are presented below [42].

Full reaction:

Oxidation reactions (anode):



CO and hydrocarbons can also be used in SOFC at high temperatures, thus a water gas shift reaction is possible:



and the steam reforming reaction is also possible:

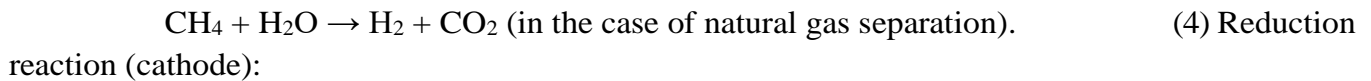

4.1.2. Direct Methanol Fuel Cell (DMFC)

Methanol can be directly employed as fuel in the FC in a DMFC system. Methanol is an organic fuel produced from coal or agricultural products. In DMFCs, both the cathode and the anode are platinum or platinum-adopted catalysts. The electrolyte solution used is trifluoromethane sulfonic acid. A DMFC is an example of a low temperature non-fuel flexible fuel cell. These fuel cells were initially implemented in small portable electronic devices, such as laptops and cell phones [43]. Compared to the PEMFC, the DMFC has lower density and efficiency.

4.1.3. Phosphoric Acid Fuel Cell (PAFC)

PAFCs rely on an acidic electrolyte, as with PEMFCs, to conduct hydrogen ions. The reactions in the anode and the cathode are the same as the PEMFC reactions. Phosphoric acid (H_3PO_4) is a viscous liquid that is contained by capillarity in the FC in a porous silicon carbide matrix. PAFCs are medium temperature fuel cells that conduct hydrogen ions, thus they are not as fuel-flexible as the high-temperature fuel cells that conduct oxidizing ions (e.g., O^- , CO^-). While PAFCs are predominantly used for stationary power, they have also been implemented in some large-scale vehicles, such as public buses [44]. The overall reaction can be characterized as follows:



The half reaction associated with the phosphoric acid fuel cell is as follows: Oxidation reaction:

Reduction reaction:

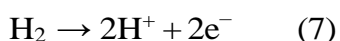

4.1.4. Polymer Electrolyte Membrane Fuel Cell (PEMFC)

Solid polymer membranes are used as the electrolyte in PEMFCs. The polymer membrane is perfluorosulfonic acid referred to as Nafion. This polymer membrane is acidic; hence, the ions transported are hydrogen ions or protons. The PEMFC is fueled with pure hydrogen, and the oxidant is air or pure oxygen. PEMFCs are low temperature fuel cells that conduct hydrogen ions (H^+), making them not fuel-flexible. These fuel cells are the most widely used in the transportation sector because they are low temperature FCs, operating around 80°C , thus they have relatively short starting and stopping times. Another advantage to PEMFCs is that they have very high efficiency and power density in the vehicle engine size class [45]. These features are well-suited to a vehicle power source where power density is desired and the dynamic power demands are significant. Some of the drawbacks to PEMFCs include a higher risk of CO poisoning and that they require cooling.

The overall chemical reaction for PEMFC is:



The chemical half reactions for the PEMFC are as follows: Oxidation reaction:

Reduction reaction:

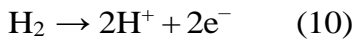

The PEMFC in an electric vehicle is taking the role of the internal combustion engine in a conventional vehicle, as it is the driving power source in the FC electric vehicle. Thus far, the PEMFC is the only fuel cell found to be suitable for automobiles. By pairing PEMFCs with rechargeable batteries, a hybrid vehicle is created that is competitive with both battery electric and fossil fuel vehicles. The electric motor, the battery, and the PEMFC are the three interdependent parts of this hybrid vehicle [46]. Figure 3 shows the basic structure of an FC-based electrical vehicle.

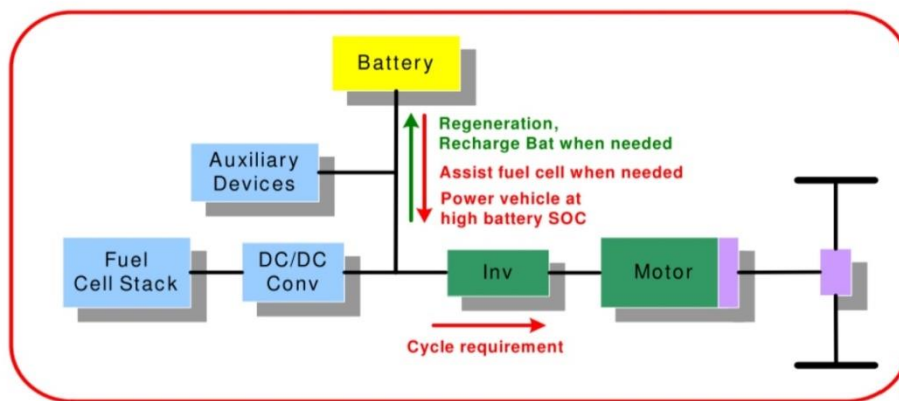

Figure 3. Basic structure of fuel cell based electric vehicle [47].

Different configurations of the hybrid electric vehicle are discussed in the following section.

4.1.5. Alkaline Fuel Cells (AFC)

AFCs use an aqueous solution of potassium hydroxide (KOH) as the electrolyte to conduct ions between electrodes. Since the electrolyte is alkaline, the ion conduction mechanism is different from PEMFCs. The ion carried by the alkaline electrolyte is a hydroxide ion (OH⁻), which affects several other aspects of the FC.

The half reactions are as follows: Oxidation:

Reduction:

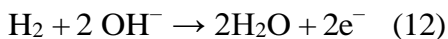

Water is required at the cathode by the oxygen reduction, thus water management is an important issue that is sometimes resolved by using waterproof electrodes and keeping the water in the electrolyte. The cathode reaction uses water from the electrolyte, whereas the anode reaction rejects its produced water. The excess water (2 mol per reaction) is evaporated outside the stack. AFCs can operate over a wide range of pressures and temperatures, from 0.22 to 4.5 MPa and 80 to 230 °C, respectively. High-temperature AFCs also make use of a highly concentrated electrolyte—highly concentrated enough that the ion transport mechanism changes from an aqueous solution to molten salt [48].

4.1.6. Unitized Reversible Fuel Cell

A unitized reversible FC (URFC) is an energy-storage device that performs in water-electrolysis mode (EC mode) to produce hydrogen and works in FC mode to generate electricity. During the mode switching of the URFC, a reversible electrochemical reaction takes place that causes the change in temperature [49].

Research on URFCs found pre-reactant switching, oxygen flow rate, hydrogen flow rate, and time interval length makes the URFC more efficient and reliable. The water accumulation in URFCs is a major problem, as it decreases the mass flow rate of reactants in FC mode. It also affects the mode switching in URFC. The residual water left during EC mode and the water produced during FC mode should be eliminated to facilitate smooth mode switching. Gas purging has been used to remove the water at the proton exchange membrane at the end of the FC operation [50]. Gas purge time increases with a decrease in the cell temperature. The gas purge flow rate should be greater than the purging time. Due to the high flow rates, the water droplets in the PEM can be pulled away from it. In FC mode, the mass flow rate of reactants is affected by the water content in the cell. To make the successful mode switching process from electrolysis mode to fuel cell mode, enough time should be provided. Allowing adequate time for gas purging enhances the mass flow rate, which helps the FC start up. The water in the channel is pushed by the oxygen gas, but the water in the oxygen side is still present due to the increased amount of time required for water electrolysis to occur. Pre-reactant switching is the method where the reactant gases (oxygen and hydrogen) are switched on before transitioning to the FC mode. By supplying the oxygen to the FC before the current supply, the residual water stored in the channels and the gas diffusion layer made during EC mode is eliminated. The gas must be supplied 180 s before the current transition to FC mode [51]. This will effectively consume the residual water at end of EC mode.

5. Fuel Cell Hybrid Vehicles

The development of one important aspect of the fuel cell vehicle—the electric motor—dates back to the early 19th century. Although electric vehicles were a strong contender in the early 20th century to become a mainstream transportation method, the ICE vehicle eventually won out due to the short range and the high cost of electric vehicles. Additionally, the discovery of Texan oil reduced the price of gasoline, thus it became affordable to the average consumer, which caused fuel cell and electric vehicles to take a backseat to the ICE vehicle for most of the last 100 years [47]. The oil embargo in 1973 kick-started a renewed interest in FC power for personal transportation applications, as governments looked to mitigate their dependence on petroleum imports. In the early 1970s, K. Kordesch [52] modified a sedan to operate from a 6-kW FC and a lead acid battery pack. The automobile was driven on public roads for about three years. In 1993, Ballard launched a fuel cell-powered light-duty transit bus using a 120-kW FC system, followed by a heavy-duty transit bus using a 200-kW FC system in 1995. In 1994 and 1995, H-Power built three fuel cell-battery hybrid buses, each using a 50-kW FC and a 100-kW nickel-cadmium battery [53]. The importance of these releases was to make FC technology understandable to key decision makers in industry and government. These buses helped to prove that fuel cells would work in the real world. Fleet-vehicle operations, such as buses and delivery services, were early adopters of fuel cell technology due to the ease of centralized refueling and the reduced requirement for a high range capability between fill-ups. Trials of FC powered buses have occurred in Vancouver and Chicago, as well as in other cities in Europe and North America [54]. In July 2005, the first FC vehicle was leased to a family in California as an important step in getting more fuel cell vehicles on the road. However, many obstacles remain to be overcome before the FC vehicle can become a mainstream form of transportation. An obvious issue is the need for a hydrogen infrastructure to enable refueling of the vehicles. Hydrogen filling stations currently exist in many countries around the world, such as Canada, the USA, Iceland, Japan, Singapore, and Germany. Though these stations are currently not widespread enough to allow large numbers of people to begin driving FCVs, it is expected that more hydrogen infrastructure will be built as more FCVs become

commercially available. Hydrogen FCVs have evolved significantly; currently, they can drive between 311 to 597 miles on a full tank. The development of these vehicles is increasing, but they still require significant improvements [14].

It should be noted that FCEVs are more promising in city bus applications due to two reasons—the supply of hydrogen is not crucial, because the buses refuel in one place, hence only one refilling point is required, and the price of FCs. FCs are still expensive, therefore it makes more sense to buy them for vehicles that are in use for many hours each day [55]. As of June 2018, there have been more than 6500 FCVs delivered to consumers. California was the leading market for FCVs, with nearly 3000 vehicles being delivered due to it having the largest network of hydrogen refueling stations (HRS) [56]. In Europe, Germany’s Linde AG and France’s Air Liquide have been working together to increase Germany’s stations from 15 to 100 by 2017 and to 400 by 2023. About 1000 HRS would be required to provide full coverage in countries such as Germany or France, with a cost of 1.5 to 2 billion euro [57,58]. FCV sales volumes are projected to be significant, but only in the long term, even with a favorable climate-policy scenario. Figure 4 shows FCV sales volume anticipations based on a long-term powertrain mix scenario (million annual units) [59]. Considering a similar scenario, the international energy agency (IEA) anticipates an FCV market share of about 17% by 2050 (35 million annual unit sales) [60].

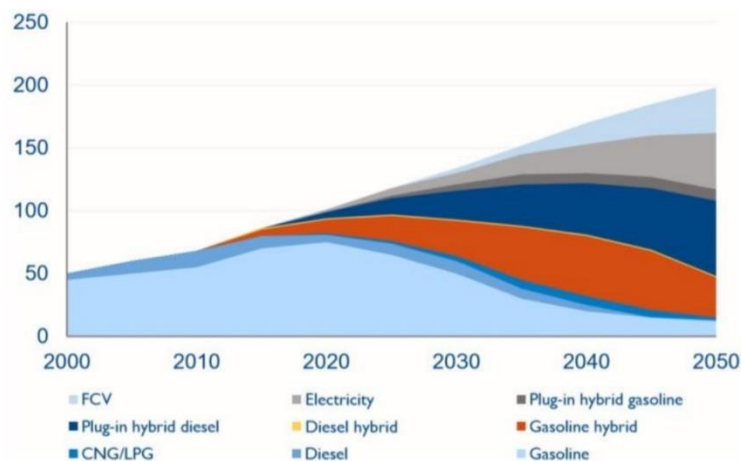

Figure 4. Fuel cell vehicle (FCV) sales volume. Source: IEA. All rights reserved. [59].

Another option to increase the HRS prevalence is to use electrolysis at refueling stations to convert electricity from the grid into hydrogen. This idea could be extended to residential applications, where people would have a hydrogen refueling station in their own homes [61–63]. The obstacles associated with developing an adequate hydrogen infrastructure brings up another important question—where will the hydrogen come from? Although hydrogen is the most abundant element in the universe, it rarely exists alone in nature. Today, hydrogen is mostly produced by reforming natural gas. In this way, pollutants can be captured if the reforming is done at a central plant. However, other options, such as direct solar hydrogen from methane at landfills and hydrogen from bacteria [64], are continually being explored. If electrolysis is used to generate hydrogen, there may have to be an increase in electricity generation to satisfy the need for hydrogen, though the increase may be small, since hydrogen can be produced during off-peak times (e.g., overnight). Methods to generate electricity that have a minimal impact on the environment include nuclear, wind, solar, hydro, and geothermal. It is often said that, at the beginning of the hydrogen economy,

most of the hydrogen will still be reformed from natural gas, but as time goes by, society will move towards more ideal sources of energy, such as wind and solar [65]. Although generation and transportation of hydrogen is a major issue in the deployment of fuel cell vehicles, many diverse ideas are being developed to solve the problem. Other obstacles for fuel cell vehicles include improving on-board hydrogen storage, improving fuel cell and battery durability, and increasing the efficiency and the performance of a fuel cell vehicle. The last barrier to commercialization is cost—a true challenge—as fuel cells are still extremely expensive today. Many parts used to work with fuel cells (e.g., power electronic converters) must be custom-made and can be very expensive as a result [66]. However, these costs will decrease as technological processes are improved and components are mass-produced.

5.1. Parallel Hybrid

One of the earlier hybrid drive train designs was the parallel hybrid architecture. In this configuration, both the internal combustion engine and the electric motor can be used to power the vehicle independent of one another. The ICE has a low torque output at low speeds, therefore in stop-and-go drive cycles, the ICE is extremely inefficient. However, electric motors provide almost instantaneous torque, making them ideal for stop-and-go drive cycles. Implementing a parallel hybrid system allows each power source or both to operate at varying degrees when it is most efficient in the drive cycle [35]. For example, during low speeds and stop-and-go cycles, the electric motor would primarily be used, and the internal combustion engine would be mostly off for efficiency reasons. Conversely, during steady-state highway conditions, the electric motor would be off, while the ICE would power the vehicle to induce a long driving range by utilizing the high energy density of the fuel [65]. In the parallel configuration, one can also operate both the ICE and the electric motor together when the torque demand is greater than the torque produced by either the ICE or the electric motor independently [66]. Since both power sources can be operated in unison when torque demands are high, it allows both the engine and the motor to be scaled down in size, since most of the time the drive cycle will not have a high torque demand. Reducing the size of both motors can further increase the overall efficiency of the parallel design. Another advantage to the parallel hybrid drive train architecture is the ability to harvest energy through deceleration in the drive cycle with the implementation of regenerative braking. Regenerative braking is not exclusive to parallel hybrid architecture, rather, almost all hybrids can deploy regenerative braking to harvest what would otherwise be wasted heat energy from the mechanical brakes [67]. Regenerative braking works by converting the electric motor into a generator during stops and decelerations in the drive cycle; this energy then gets stored in the batteries of the vehicle to be used later in the drive cycle [68]. A visual representation of a parallel hybrid drive train is depicted below in Figure 5 [69].

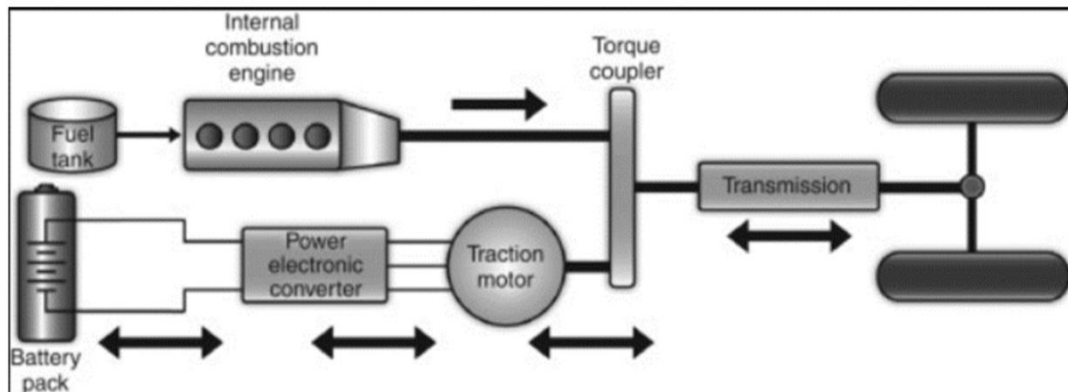

Figure 5. Parallel hybrid configuration [69].

5.2. Series Hybrid

A series hybrid drive train architecture differs from a parallel hybrid drive train in that the two power sources are no longer independently able to power the vehicle. In this configuration, generally the ICE will act as a charger for the batteries that supply electricity to the electric motor—the only source to propel the vehicle [70]. One of the advantages of this design is that there is no need for a transmission, since the ICE is not powering the vehicle directly. Eliminating the transmission from the engine system reduces the weight of the vehicle, which directly correlates to increased efficiency. In a series configuration, the ICE does not have to account for any of the transient dynamics in the drive cycle as it would in a parallel configuration. Because of this, the engine can be operated at a steady state at its most efficient rpm, further increasing its efficiency. In a series configuration, there is more flexibility regarding the implementation of alternative energy devices. For example, for this project, the ICE was replaced with a hydrogen FC. In a series hybrid, the ICE converts chemical energy to mechanical energy and then to electrical energy, thus it is actually more efficient to use an FC to convert directly from chemical energy to electrical energy to charge the battery pack. This is one of the main reasons the decision was made to implement a series configuration in this project. It should be noted that a fuel cell can be used in a parallel configuration as well. However, to achieve parallel use, the fuel cell would need to be robust enough to handle the transient dynamics created by the drive cycle. Most fuel cells have high enough power density to handle transient dynamic loading well. Usually, fuel cells are required to operate near steady-state conditions, which makes them ideal for series hybrid architectures [71–75]. An example of a series hybrid configuration with an ICE is depicted below in Figure 5.

The series hybrid design can also support regenerative braking to recover energy during stops and decelerations the same way the parallel hybrid does by converting the motor into a generator during these instances in the drive cycle. A drawback to the series hybrid design is that the motor is required to be larger, since there is no way to use both power sources during a hard acceleration.

5.3. Series-Parallel Hybrid

The series-parallel hybrid is a combination of both series and parallel hybrid drive train configurations. In a series-parallel hybrid, both the electric motor and the ICE can power the vehicle independently or jointly. The ICE can divide its power between driving the car and charging the batteries simultaneously [76]. This configuration provides the most control flexibility, since the modes of operation can be optimized to compensate for the current drive cycle. However, one of the drawbacks to this design is the amount of hardware required. Since the ICE must be able to drive the vehicle, a transmission is required,

and a generator is required to enable the ICE to charge the batteries. The series-parallel design has all the benefits of both the series design and the parallel design, which makes it more flexible to different drive cycles; however, it also has all the drawbacks of both designs [77–81]. An example of a series-parallel hybrid configuration is shown below in Figure 6.

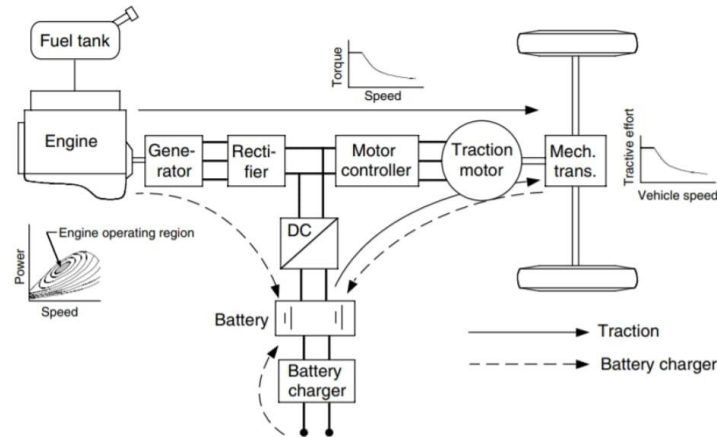

Figure 6. Series hybrid configuration [35].

6. Control Strategies to Make FCV More Efficient

The disadvantage of FCV, such as low power density and low power response, can be overcome by implementing super capacitors (SCAPS) and batteries (BATs) with a fuel cell in an FCV [82–84]. An FCEV has a three phase traction motor, an energy storage system, a direct current (DC) bus, and auxiliary devices. The energy is transferred in the order of FC-BAT-SCAP, and an inverter is used to control the output energy to the traction motor and the output from the SCAP. The most common control strategies used by these controllers are given below.

1. Peaking Power Source Strategy (PPSS)
2. Operating Mode Control Strategy (OMCS)
3. Fuzzy Logic Control Strategy (FLCS)
4. Equivalent Consumption Minimization Strategy (ECMS)

6.1. Peaking Power Source Strategy (PPSS)

In PPSS, the controllers, the wheels, the traction motor, and the pedals are electronically interfaced to collect the signal. The power and the torque are controlled by the vehicle controller based on the commands from the gas and the brake pedals. Based on the demanded power, the energy alters between FC and PPS to meet the vehicle power requirement. The required energy is provided either from the FC, with the PPS, or both, and according to the demand from the driver to respond quickly, traction is designed to control the output power [85,86].

6.2. Operating Mode Control Strategy (OMCS)

OMCS manages the power variances and the power control between the FC and the BAT. In the discharge mode, the vehicle's power demand (P_{demand}) may be less or more than the nominal P_{FC} , depending on the acceleration. If P_{demand} is lower than the nominal P_{FC} , the required energy is provided by FC. If P_{demand} is more than the nominal P_{FC} , the required energy is generated by both FC and from BAT. In charging mode, P_{demand} is the nominal P_{FC} , and the FC both provides the power demand and charges the BAT. P_{demand} is much smaller than the nominal P_{FC} in the fast charge mode. In this condition, the FC supplies both P_{demand} and the power to all units that require extra energy [87,88].

6.3. Fuzzy Logic Control Strategy (FLCS)

To control the energy storage system and enhance the efficiency of the FCV, FLCS is applied. While the power levels of SCAP and BAT state of charging (SOC) are low (L_{SOC}), P_{DC} ought to be maximized (DC_{max}). When SCAP and BAT power levels are high, P_{DC} must either be at the minimum level (DC_{min}) or the middle level (DC_{middle}), depending on P_{demand} . The goal is to maintain the optimum power levels of SCAP and BAT while meeting P_{demand} , allowing operation at a nominal P_{FC} .

6.4. Equivalent Consumption Minimization Strategy (ECMS)

The ECMS is applied to manage the energy resource in the energy storage device. The electricity consumption of SCAP and BAT is converted into the equivalent hydrogen consumption. Moreover, ECMS can use electrical energy supplied by energy storage systems such as the SCAP and the BAT as hydrogen from the FC, if necessary, with the concept of equivalent fuel consumption [89].

7. Conclusions

In this paper, an investigation into hydrogen-based energy generation using fuel cells and their utilization in hybrid vehicles was conducted. Various types of FCs and their applications were analyzed, namely the application of FCs in hybrid vehicles. FCs with adequate control strategies could become the more advantageous choice for applications in vehicles over batteries alone. Hydrogen fuel cells will play a significant role in the transportation industry in the near future. The price of fuel cells will reduce when producing fuel cells in large quantities and commercializing them. We could expect fuel cell-based transportation, power plants, and electricity generators to become prominent in the coming decades.

Author Contributions: Conceptualization, S.E.H., writing—original draft preparation, Y.M., B.B., H.A., B.T.F.S.; writing—review and editing, T.A., J.K.

Funding: This research received no external funding.

Conflicts of Interest: The authors declare no conflict of interest.

Abbreviation

AFC	Alkaline Fuel Cell
BAT	Battery
BEV	Battery electric vehicle
CH ₂	Compressed Hydrogen
CV	Conventional vehicle
DMFC	Direct methanol fuel cell
ECMS	Equivalent Consumption Minimization Strategy
FC	Fuel cell
FCEV	Fuel cell electric vehicle
FCV	Fuel cell vehicle
FLCS	Fuzzy Logic Control Strategy
HRS	Hydrogen refueling stations
ICE	Internal combustion engine
LH ₂	Liquid Hydrogen
OMCS	Operating Mode Control Strategy
PAFC	Phosphoric acid fuel cell
PEMFC	Polymer electrolyte membrane fuel cell
PPSS	Peaking Power Source Strategy
SCAP	Super Capacitor
SOC	State of Charge
SOFC	Solid oxide fuel cells
URFC	Unitized regenerative fuel cell
YSZ	Yttrium stabilized zirconia

References

1. Hosseini, S.E.; Andwari, A.M.; Wahid, M.A.; Bagheri, G. A review on green energy potentials in Iran. *Renew. Sustain. Energy Rev.* **2013**, *27*, 533–545. [[CrossRef](#)]

2. Granovskii, M.; Dincer, I.; Rosen, M.A. Greenhouse gas emissions reduction by use of wind and solar energies for hydrogen and electricity production: Economic factors. *Int. J. Hydrogen Energy* **2007**, *32*, 927–931. [[CrossRef](#)]
3. Derbeli, M.; Barambones, O.; Sbita, L.; Derbeli, M.; Barambones, O.; Sbita, L. A Robust Maximum Power Point Tracking Control Method for a PEM Fuel Cell Power System. *Appl. Sci.* **2018**, *8*, 2449. [[CrossRef](#)]
4. Hosseini, S.E.; Wahid, M.A.; Aghili, N. The scenario of greenhouse gases reduction in Malaysia. *Renew. Sustain. Energy Rev.* **2013**, *28*, 400–409. [[CrossRef](#)]
5. Eriksson, E.L.V.; Gray, E.M.A. Optimization and integration of hybrid renewable energy hydrogen fuel cell energy systems—A critical review. *Appl. Energy* **2017**, *202*, 348–364. [[CrossRef](#)]
6. Heywood, J.B. *Internal Combustion Engine Fundamentals*; McGraw-Hill Education: New York, NY, USA, 1988.
7. Costilla-Reyes, A.; Erbay, C.; Carreon-Bautista, S.; Han, A.; Sánchez-Sinencio, E. A Time-Interleave-Based Power Management System with Maximum Power Extraction and Health Protection Algorithm for Multiple Microbial Fuel Cells for Internet of Things Smart Nodes. *Appl. Sci.* **2018**, *8*, 2404. [[CrossRef](#)]
8. Kerviel, A.; Pesyridis, A.; Mohammed, A.; Chalet, D.; Kerviel, A.; Pesyridis, A.; Mohammed, A.; Chalet, D. An Evaluation of Turbocharging and Supercharging Options for High-Efficiency Fuel Cell Electric Vehicles. *Appl. Sci.* **2018**, *8*, 2474. [[CrossRef](#)]
9. Wang, C.; Nehrir, M.H.; Gao, H. Control of PEM Fuel Cell Distributed Generation Systems. *IEEE Trans. Energy Convers.* **2006**, *21*, 586–595. [[CrossRef](#)]
10. Somekawa, T.; Nakamura, K.; Kushi, T.; Kume, T.; Fujita, K.; Yakabe, H. Examination of a high-efficiency solid oxide fuel cell system that reuses exhaust gas. *Appl. Therm. Eng.* **2017**, *114*, 1387–1392. [[CrossRef](#)]
11. Ayad, M.Y.; Becherif, M.; Henni, A. Vehicle hybridization with fuel cell, supercapacitors and batteries by sliding mode control. *Renew. Energy* **2011**, *36*, 2627–2634. [[CrossRef](#)]
12. Chakraborty, U.K. A New Model for Constant Fuel Utilization and Constant Fuel Flow in Fuel Cells. *Appl. Sci.* **2019**, *9*, 1066. [[CrossRef](#)]
13. Giorgi, L.; Leccese, F. Fuel Cells: Technologies and Applications. *Open Fuel Cells J.* **2013**, *6*, 1–20. [[CrossRef](#)]
14. Offer, G.J.; Howey, D.; Contestabile, M.; Clague, R.; Brandon, N.P. Comparative analysis of battery electric, hydrogen fuel cell and hybrid vehicles in a future sustainable road transport system. *Energy Policy* **2010**, *38*, 24–29. [[CrossRef](#)]
15. Choi, H.; Shin, J.; Woo, J. Effect of electricity generation mix on battery electric vehicle adoption and its environmental impact. *Energy Policy* **2018**, *121*, 13–24. [[CrossRef](#)]
16. Aceves, S.M.; Berry, G.D.; Weisberg, A.H.; Espinosa-Loza, F.; Perfect, S.A. Advanced concepts for vehicular containment of compressed and cryogenic hydrogen. In Proceedings of the 16th World Hydrogen Energy Conference 2006 (WHEC 2006), Lyon, France, 13–16 June 2006.
17. Michel, F.; Fieseler, H.; Allidiers, L. Liquid Hydrogen Technologies for Mobile Use. In Proceedings of the 16th World Hydrogen Energy Conference 2006 (WHEC 2006), Lyon, France, 13–16 June 2006.
18. Paggiaro, R.; Michl, F.; Bénard, P.; Polifke, W. Cryo-adsorptive hydrogen storage on activated carbon. II: Investigation of the thermal effects during filling at cryogenic temperatures. *Int. J. Hydrogen*

- Energy* **2010**, *35*, 648–659. [[CrossRef](#)]
19. Hosseini, S.E.; Wahid, M.A. Hydrogen production from renewable and sustainable energy resources: Promising green energy carrier for clean development. *Renew. Sustain. Energy Rev.* **2016**, *57*. [[CrossRef](#)]
20. Boretti, A. Novel dual fuel diesel-ammonia combustion system in advanced TDI engines. *Int. J. Hydrogen Energy* **2017**, *42*, 7071–7076. [[CrossRef](#)]
21. Veziroglu, A.; MacArio, R. Fuel cell vehicles: State of the art with economic and environmental concerns. *Int. J. Hydrogen Energy* **2011**, *36*, 25–43. [[CrossRef](#)]
22. Hosseini, S.E.; Wahid, M.A.; Ganjehkaviri, A. An overview of renewable hydrogen production from thermochemical process of oil palm solid waste in Malaysia. *Energy Convers. Manag.* **2015**, *94*, 415–429. [[CrossRef](#)]
23. Hosseini, S.E.; Abdul Wahid, M.; Jamil, M.; Azli, A.A.M.; Mohamad, F.M. A review on biomass-based hydrogen production for renewable energy supply. *Int. J. Energy Res.* **2015**, *39*, 1597–1615. [[CrossRef](#)]
24. Hibino, T.; Kobayashi, K.; Ito, M.; Ma, Q.; Nagao, M.; Fukui, M.; Teranishi, S. Efficient Hydrogen Production by Direct Electrolysis of Waste Biomass at Intermediate Temperatures. *ACS Sustain. Chem. Eng.* **2018**, *6*, 9360–9368. [[CrossRef](#)]
25. Hibino, T.; Kobayashi, K.; Lv, P.; Nagao, M.; Teranishi, S.; Mori, T. An Intermediate-Temperature Biomass Fuel Cell Using Wood Sawdust and Pulp Directly as Fuel. *J. Electrochem. Soc.* **2017**, *164*, F557–F563. [[CrossRef](#)]
26. Hibino, T.; Kobayashi, K.; Ito, M.; Nagao, M.; Fukui, M. Applied Catalysis B: Environmental Direct electrolysis of waste newspaper for sustainable hydrogen production: An oxygen-functionalized porous carbon anode. *Appl. Catal. B Environ.* **2018**, *231*, 191–199. [[CrossRef](#)]
27. Hibino, T.; Kobayashi, K.; Nagao, M.; Teranishi, S. Hydrogen Production by Direct Lignin Electrolysis at Intermediate Temperatures. *ChemElectroChem* **2017**, *4*, 3032–3036. [[CrossRef](#)]
28. Hori, T.; Ma, Q.; Kobayashi, K.; Nagao, M. Electrolysis of humidified methane to hydrogen and carbon dioxide at low temperatures and voltages. *Int. J. Hydrogen Energy* **2019**, *44*, 2454–2460. [[CrossRef](#)]
29. Alternative Fuels Data Center: How Do Fuel Cell Electric Vehicles Work Using Hydrogen? Available online: <https://afdc.energy.gov/vehicles/how-do-fuel-cell-electric-cars-work> (accessed on 21 May 2019).
30. Devrim, Y.; Devrim, H.; Eroglu, I. Development of 500 W PEM fuel cell stack for portable power generators. *Int. J. Hydrogen Energy* **2015**, *40*, 7707–7719. [[CrossRef](#)]
31. Davis, C.; Edelstein, B.; Evenson, B.; Brecher, A.; Cox, D. Hydrogen Fuel Cell Vehicle Study. Presented at the Panel on Public Affairs (POPA), American Physical Society, 12 June 2003.
32. Atkinson, K.; Roth, S.; Hirscher, M.; Grünwald, W. Carbon nanostructures: An efficient hydrogen storage medium for fuel cells. *Fuel Cells Bull.* **2001**, *4*, 9–12. [[CrossRef](#)]
33. Das, L.M. Hydrogen-fueled internal combustion engines. *Compend. Hydrog. Energy* **2016**, 177–217. [[CrossRef](#)]
34. Chen, P.; Xiong, Z.; Luo, J.; Lin, J.; Tan, K.L. Interaction of hydrogen with metal nitrides and imides. *Nature* **2002**, *420*, 302–304. [[CrossRef](#)]

35. Ehsani, M.; Gao, Y.; Longo, S.; Ebrahimi, K. *Modern Electric, Hybrid Electric, and Fuel Cell Vehicles, Third Edition*; CRC Press: Boca Raton, FL, USA, 2018; ISBN 9780429504884.
36. Jorgensen, S.W. Hydrogen storage tanks for vehicles: Recent progress and current status. *Curr. Opin. Solid State Mater. Sci.* **2011**, *15*, 39–43. [[CrossRef](#)]
37. Greene, D.L.; Leiby, P.N.; James, B.D.; Perez, J.; Melandez, M.; Milbrandt, A.; Unnasch, S.; Rutherford, D. *Analysis of the Transition to Hydrogen Fuel Cell Vehicles and the Potential Hydrogen Energy Infrastructure Requirements*; Oak Ridge National Lab. (ORNL): Oak Ridge, TN, USA, 2008.
38. Kirubakaran, A.; Jain, S.; and Nema, R.K. The PEM Fuel Cell System with DC / DC Boost Converter: Design, Modeling and Simulation. *Int. J. Recent Trends Eng.* **2009**, *1*, 157.
39. O’Hayre, R.P.; Cha, S.-W.; Colella, W.G.; Prinz, F.B. *Fuel Cell Fundamentals*; John Wiley & Sons: Hoboken, NJ, USA, 2016; ISBN 9781119113805.
40. Reschiotto, D. Effects of Anode Fuel Recirculation on SOFCs Fuelled with Biogas. Master’s Thesis, Politecnico di Torino, Torino, Italy, 2018.
41. Yang, G.; Jung, W.; Ahn, S.-J.; Lee, D.; Yang, G.; Jung, W.; Ahn, S.-J.; Lee, D. Controlling the Oxygen Electrocatalysis on Perovskite and Layered Oxide Thin Films for Solid Oxide Fuel Cell Cathodes. *Appl. Sci.* **2019**, *9*, 1030. [[CrossRef](#)]
42. NFCRC Tutorial: Solid Oxide Fuel Cell (SOFC). Available online: <http://www.nfcrc.uci.edu/3/TUTORIALS/EnergyTutorial/sofc.html> (accessed on 16 October 2018).
43. Barbir, F. *PEM Fuel Cells: Theory and Practice*, 2nd ed.; Academic Press: Cambridge, MA, USA, 2013; ISBN 9780123877109.
44. Yamarone, R. *The Trader’s Guide to Key Economic Indicators*; Bloomberg Press: Hoboken, NJ, USA, 2004; ISBN 1576601390.
45. Srinivasan, S. Fuel cells: From fundamentals to applications. In *Fuel Cells*; Springer Science & Business Media: Boston, MA, USA, 2006; pp. 3–25.
46. Wilberforce, T.; El-Hassan, Z.; Khatib, F.N.; Al Makky, A.; Baroutaji, A.; Carton, J.G.; Olabi, A.G. Developments of electric cars and fuel cell hydrogen electric cars. *Int. J. Hydrogen Energy* **2017**, *42*, 25695–25734. [[CrossRef](#)]
47. Briguglio, N.; Andaloro, L.; Ferraro, M.; Antonucci, V. Fuel Cell Hybrid Electric Vehicles. In *Electric Vehicles, The Benefits and Barriers*; InTech: London, UK, 2011.
48. Garche, J.; Jörissen, L. Applications of Fuel Cell Technology: Status and Perspectives. *Electrochem. Soc. Interface* **2015**, *24*, 39–43. [[CrossRef](#)]
49. Bhosale, A.C.; Mane, S.R.; Singdeo, D.; Ghosh, P.C. Modeling and experimental validation of a unitized regenerative fuel cell in electrolysis mode of operation. *Energy* **2017**, *121*, 256–263. [[CrossRef](#)]
50. Zhang, Y.; Zhang, H.; Ma, Y.; Cheng, J.; Zhong, H.; Song, S.; Ma, H. A novel bifunctional electrocatalyst for unitized regenerative fuel cell. *J. Power Sources* **2010**, *195*, 142–145. [[CrossRef](#)]
51. Ito, H.; Miyazaki, N.; Ishida, M.; Nakano, A. ScienceDirect Efficiency of unitized reversible fuel cell systems. *Int. J. Hydrogen Energy* **2016**, *41*, 5803–5815. [[CrossRef](#)]
52. Shukla, A.K.; Jackson, C.L.; Scott, K. The Promise of Fuel Cell-Based Automobiles. *Bull. Mater. Sci.* **2003**, *26*, 207–214. [[CrossRef](#)]
53. Stefan, J.; Minott, S.J.; Norman, R.; Scott, N.R. Feasibility of Fuel Cells for Energy Conversion on Dairy Farms. In Proceedings of the ASABE Annual Meeting, Sacramento, CA, USA, July 29–August 1 2001.

54. Chu, S.; Majumdar, A. Opportunities and challenges for a sustainable energy future. *Nature* **2012**, *488*, 294–303. [[CrossRef](#)]
55. Mahmoud, M.; Garnett, R.; Ferguson, M.; Kanaroglou, P. Electric buses: A review of alternative powertrains. *Renew. Sustain. Energy Rev.* **2016**, *62*, 673–684. [[CrossRef](#)]
56. Hardman, S.; Tal, G. Who are the early adopters of fuel cell vehicles? *Int. J. Hydrogen Energy* **2018**, *43*, 17857–17866. [[CrossRef](#)]
57. Schwelm, G. Hydrogenics fueling installations in Germany, France. *Fuel Cells Bull.* **2009**, *2009*, 7. [[CrossRef](#)]
58. Robledo, C.B.; Oldenbroek, V.; Abbruzzese, F.; van Wijk, A.J.M. Integrating a hydrogen fuel cell electric vehicle with vehicle-to-grid technology, photovoltaic power and a residential building. *Appl. Energy* **2018**, *215*, 615–629. [[CrossRef](#)]
59. International Energy Agency. Available online: <http://www.iea.org/> (accessed on 20 January 2017).
60. Arena, F.; Spera, D.; Laguardia, F. What's in the Future for Fuel Cell Vehicles? Arthur D Little: Boston, MA, USA.
61. Hisschemöller, M.; Bode, R.; van de Kerckhof, M. What governs the transition to a sustainable hydrogen economy? Articulating the relationship between technologies and political institutions. *Energy Policy* **2006**, *34*, 1227–1235. [[CrossRef](#)]
62. Brey, J.J.; Carazo, A.F.; Brey, R. Exploring the marketability of fuel cell electric vehicles in terms of infrastructure and hydrogen costs in Spain. *Renew. Sustain. Energy Rev.* **2018**, *82*, 2893–2899. [[CrossRef](#)]
63. Thomas, C.E. Fuel cell and battery electric vehicles compared. *Int. J. Hydrogen Energy* **2009**, *34*, 6005–6020. [[CrossRef](#)]
64. Barbosa, M.J.; Rocha, J.M.; Tramper, J.; Wijffels, R.H. Acetate as a carbon source for hydrogen production by photosynthetic bacteria. *J. Biotechnol.* **2001**, *85*, 25–33. [[CrossRef](#)]
65. Emadi, A.; Rajashekara, K.; Williamson, S.S.; Lukic, S.M. Topological Overview of Hybrid Electric and Fuel Cell Vehicular Power System Architectures and Configurations. *IEEE Trans. Veh. Technol.* **2005**, *54*, 763–770. [[CrossRef](#)]
66. Liu, Y.-L.; Tong, C.-C.; Jwo, W.-S.; Lin, S.-J. Design an Intelligent Neural-Fuzzy Controller for Hybrid Motorcycle. In *NAFIPS 2007. 2007 Annual Meeting of the North American Fuzzy Information Processing Society*; IEEE: San Diego, CA, USA, 24–27 June 2007; pp. 283–288.
67. Ahn, J.K.; Jung, K.H.; Kim, D.H.; Jin, H.B.; Kim, H.S.; Hwang, S.H. Analysis of a regenerative braking system for Hybrid Electric Vehicles using an Electro-Mechanical Brake. *Int. J. Automot. Technol.* **2009**, *10*, 229–234. [[CrossRef](#)]
68. Gao, Y.; Chen, L.; Ehsani, M. Investigation of the Effectiveness of Regenerative Braking for EV and HEV. In *SAE Technical Paper*; SAE International: Warrendale, PA, USA, 1999.
69. Arora, A.; Medora, N.K.; Livernois, T.; Swart, J. Safety of Lithium-Ion Batteries for Hybrid Electric Vehicles. *Electr. Hybrid Veh.* **2010**, 463–491. [[CrossRef](#)]
70. Walters, J.; Husted, H.; Rajashekara, K. Comparative Study of Hybrid Powertrain Strategies. *SAE Trans.* **2001**, *110*, 1944–1953.
71. Hogarth, W.H.J.; Benziger, J.B. Dynamics of Autohumidified PEM Fuel Cell Operation. *J.*

Electrochem. Soc.

2006, 153, A2139. [[CrossRef](#)]

72. Hasan, A.; Guo, S.; Wahab, M. Simulation of a proton exchange membrane fuel cell. *World J. Eng.* **2011**, 8, 109–115. [[CrossRef](#)]
73. Guarnieri, M.; Moro, F. A novel circuit model of a proton exchange membrane fuel cell. *COMPEL Int. J. Comput. Math. Electr. Electron. Eng.* **2010**, 29, 1562–1572. [[CrossRef](#)]
74. Kato, M.; Henry, A.; Graham, S.; Doan, D.H.; Fushinobu, K. Molecular dynamics simulation of oxygen transport characteristics in the electrolyte membrane of PEMFC. *Int. J. Numer. Methods Heat Fluid Flow* **2018**, 28, 289–296. [[CrossRef](#)]
75. Electrochemical Society. *Journal of the Electrochemical Society*; Electrochemical Society: Pennington, NJ, USA, 1948.
76. Grammatico, S.; Balluchi, A.; Italia, D. A series-parallel hybrid electric powertrain for industrial vehicles. In *Proceedings of the Automotive Control View Project*; IEEE: Piscataway, NJ, USA, 2010.
77. Amodeo, S.J.; Chiacchiarini, H.G.; Solsona, J.A.; Busada, C.A. High-performance sensorless nonlinear power control of a flywheel energy storage system. *Energy Convers. Manag.* **2009**, 50, 1722–1729. [[CrossRef](#)]
78. Xiong, W.; Zhang, Y.; Yin, C. Optimal energy management for a series-parallel hybrid electric bus. *Energy Convers. Manag.* **2009**, 50, 1730–1738. [[CrossRef](#)]
79. Hu, X.; Murgovski, N.; Johannesson, L.; Egardt, B. Energy efficiency analysis of a series plug-in hybrid electric bus with different energy management strategies and battery sizes. *Appl. Energy* **2013**, 111, 1001–1009. [[CrossRef](#)]
80. He, X.; Jiang, Y. Review of hybrid electric systems for construction machinery. *Autom. Constr.* **2018**, 92, 286–296. [[CrossRef](#)]
81. Dreier, D.; Silveira, S.; Khatiwada, D.; Fonseca, K.V.O.; Nieweglowski, R.; Schepanski, R. Well-to-Wheel analysis of fossil energy use and greenhouse gas emissions for conventional, hybrid-electric and plug-in hybrid-electric city buses in the BRT system in Curitiba, Brazil. *Transp. Res. Part D Transp. Environ.* **2018**, 58, 122–138. [[CrossRef](#)]
82. Camara, M.B.; Gualous, H.; Gustin, F.; Berthon, A. Design and New Control of DC/DC Converters to Share Energy Between Supercapacitors and Batteries in Hybrid Vehicles. *IEEE Trans. Veh. Technol.* **2008**, 57, 2721–2735. [[CrossRef](#)]
83. Bauman, J.; Kazerani, M. An Analytical Optimization Method for Improved Fuel Cell–Battery–Ultracapacitor Powertrain. *IEEE Trans. Veh. Technol.* **2009**, 58, 3186–3197. [[CrossRef](#)]
84. Bauman, J.; Kazerani, M. A Comparative Study of Fuel-Cell–Battery, Fuel-Cell–Ultracapacitor, and Fuel-Cell–Battery–Ultracapacitor Vehicles. *IEEE Trans. Veh. Technol.* **2008**, 57, 760–769. [[CrossRef](#)]
85. Thounthong, P.; Raël, S.; Davat, B. Energy management of fuel cell/battery/supercapacitor hybrid power source for vehicle applications. *J. Power Sources* **2009**, 193, 376–385. [[CrossRef](#)]
86. Cipollone, R.; Di Battista, D.; Marchionni, M.; Villante, C. Model based Design and Optimization of a Fuel Cell Electric Vehicle. *Energy Procedia* **2014**, 45, 71–80. [[CrossRef](#)]
87. Ning, Q.; Xuan, D.; Kim, Y. Modeling and control strategy development for fuel cell hybrid vehicles. *Int. J. Automot. Technol.* **2010**, 11, 229–238. [[CrossRef](#)]
88. Bizon, N.; Thounthong, P. Fuel economy using the global optimization of the Fuel Cell Hybrid Power

Systems. *Energy Convers. Manag.* **2018**, *173*, 665–678. [[CrossRef](#)]

89. Gao, L.; Dougal, R.A.; Liu, S. Power Enhancement of an Actively Controlled Battery/Ultracapacitor Hybrid. *IEEE Trans. Power Electron.* **2005**, *20*, 236–243. [[CrossRef](#)]